

Ministry of Education and Science of Ukraine

ODESA NATIONAL UNIVERSITY OF TECHNOLOGY

International Competition of
Student Scientific Works

BLACK SEA SCIENCE 2023

PROCEEDINGS



ODESA, ONUT 2023

Ministry of Education and Science of Ukraine

Odesa National University of Technology

International Competition of Student Scientific Works

BLACK SEA SCIENCE 2023

Proceedings

Odesa, ONUT
2023

BIOPLATEAU AS A SYSTEM FOR IMPROVING THE WATER QUALITY OF SAYRAN LAKE

Authors: Lyalya Timurova¹

Anastasiya Shmikova²

Advisors: Mikhail Katkov¹

Roman Shevchenko²

¹Kazakh National Research Technical University
named after KI Satbayev (Kazakhstan)

²Odesa National University of Technology (Ukraine)

Abstract. *Sairan Lake is a recreational reservoir artificially created in the center of Almaty on the site of a former sand and gravel quarry. The Bolshaya Almatinka River fills the lake. The flow of the Bolshaya Almatinka River is seasonal. In the cold season, water is drained from the reservoir.*

Currently, there is a strong anthropogenic degradation of the recreational potential of Lake Sairan in Almaty. The lake has lost the ability to self-cleanse, at the same time, with the waters of the Bolshaya Almatinka River, an increasing amount of various pollution flows into the lake. The data of the presented studies are the starting part of the project to create an artificial bioplateau on Lake Sairan in Almaty.

The work accepts the hypothesis of restoring recreational quality through the creation of an artificial bioplateau [1], it is related to the fact that the bioplateau will allow the processing of pollutants dissolved in water. Classical water purification methods that use mechanical, physical and chemical methods are characterized by high capital intensity and high operating costs.

The considered provisions make it possible to consider the project of creating an artificial bioplateau on Lake Sairan in Almaty city as economically and environmentally more efficient in comparison with other technologies. This project will provide the necessary recreational water requirements for Lake Sairan. The project should also provide for seasonal cleaning in the bed of the Bolshaya Almatinka River.

Keywords: *Sairan Lake, Bolshaya Almatinka River, recreational reservoir, bioplateau.*

I. INTRODUCTION

Water objects on the territory of large cities should be aesthetically attractive to residents and contain the maximum possible number of recreational services, therefore all types of work aimed at ensuring these principles are of sufficient relevance.

The goal of the work: substantiation of engineering and environmental measures that will allow creating and permanently maintaining the natural-artificial recreational complex of Lake Sayran on the Bolshaya Almatynka River.

Job tasks:

- justification of the relevance of the work and the choice of research methods;
- assessment of the current state of the Bolshaya Almatynka River and Sayran Lake;
- justification of cleaning technology based on natural biological methods;

- substantiation of hydrotechnical structures that provide seasonal supply of water from the Bolshaya Almatynka River for cleaning;
- substantiation of facilities that seasonally provide water purification of the Bolshaya Almatynka River and Lake Sayran to the third quality class.

Scientific novelty: water purification of the Bolshaya Almatynka River and Lake Sayran only during the bathing season, which will eliminate the possibility of destruction of hydrotechnical structures due to possible changes in the regime of the river with a mountainous drainage area.

The work involves the construction of two dams that allow water to be directed to the bioplateau only during the bathing season, the rest of the time the bioplateau will exist only as artificial and natural aesthetic objects.

Practical meaning: the results of the work can be used in the development of engineering and ecological projects for the creation of recreation zones in the city of Almaty.

II. LITERATURE ANALYSIS

Biological treatment of polluted natural and wastewater is based on the ability of various groups of microorganisms to destroy soluble organic substances contained in wastewater in the process of their vital activity, that is, to use dissolved organic pollution of wastewater as food products, as a result of which they receive energy for their vital activities. and wastewater is freed from these pollutants.

Biological cleaning can be carried out by the following methods:

- in conditions close to natural;
- in artificially created conditions.

Biological purification in conditions close to natural ones consists in adapting natural biocenoses of soils or water bodies to receiving wastewater and natural biological oxidation of organic substances contained in wastewater using technical means.

Facilities for the biological treatment of wastewater under conditions close to natural ones are divided into facilities in which treated wastewater is filtered through a layer of soil (filtration fields and irrigation fields) and facilities that are reservoirs (bioponds) filled with treated sewage water. In buildings of the first type, the supply of oxygen occurs mainly due to its direct absorption by microorganisms from the air. In buildings of the second type, the supply of oxygen occurs mainly due to reaeration or artificial aeration. However, the low intensity of natural biochemical processes, the large area of buildings and climatic conditions limit the wide application of biological wastewater treatment methods in conditions close to natural ones.

1.1 Biological ponds

Biological pond – a natural or artificially created water object, intended for biological purification (re-treatment) of wastewater, based on the processes of self-purification of water bodies [2]. Biological reservoirs differ from natural reservoirs, where all biological processes occur spontaneously, in that all processes in them are regulated and directed by humans in the direction they need [3].

Biological reservoirs have a small depth - 0.5... 3 m; the area of an individual pond is 0.01... 50 ha. The presence of a significant water-air contact surface ensures heating of the entire water column and its mixing. This creates favorable conditions for the development of aquatic organisms that assimilate biogenic elements and enrich the water with oxygen necessary for the oxidation of organic substances.

Oxidation processes in bioponds are most effective in the warm season. When the water temperature is below 6°C, the intensity of cleaning slows down sharply, and when the temperature drops further, it is almost completely stopped. Therefore, in the winter period, after the formation of an ice cover, when oxygen does not penetrate into the water, only the wastewater in the reservoir freezes. At the same time, in flowing, non-aerated bioponds with higher aquatic vegetation, year-round purification of wastewater from a number of pollutants, in particular from SPAR and oil products, is possible [4-6].

Being the final link in the processes of sewage treatment, biological reservoirs ultimately shape the quality of water discharged into water bodies - rivers, lakes, reservoirs. Most often, bioponds are used as an independent construction for wastewater treatment [7].

Unlike artificial biological treatment facilities, biological ponds, in addition to cleaning from mineral substances and suspended particles, provide a high level of bacterial self-cleaning. In particular, the number of *Escherichia coli* in bioponds is reduced by 95.9 - 99.9% of the initial content, and helminth eggs in water that has passed through biological ponds are practically absent. Bioponds often include autonomous consumers with a small water consumption in water treatment systems. This makes it possible to combine actual water treatment and aquaculture, as well as partially pay off the costs of building and operating bioponds, making water treatment cheaper in general [8]. Biological ponds are not without disadvantages, the most important of which are the seasonality of work and low oxidation capacity, as well as the need for large areas. At the same time, in addition to their direct functions - sewage treatment, biological ponds can be a source of water for irrigation, serve as breeding of waterfowl and fish.

Biological ponds can be of natural or artificial origin. The former include natural reservoirs and wetlands (swampy areas with a slow water flow on the way to larger reservoirs), the latter include reservoirs specially created by man.

According to the nature of placement, biological ponds belong to three types [9]:

- *rigging and beam ponds* – located in basins blocked by a dam; have the shape of an elongated triangle with the base near the dam;
- *bulk rates* – located in natural recesses; lake-shaped, length and width are approximately the same;
- *dug ponds* – location is arbitrary; the configuration and dimensions depend on the shape and parameters of the excavated pit.

Based on the concentration of effluents discharged into the reservoir, the following are distinguished:

- *biological ponds with breeding* (fish hatchery) – effluents, after preliminary clarification in settling tanks, are mixed with clean river water and sent to single-stage flow ponds of 0.5-7 hectares in size. The duration of water stay in them is 8-12 days;

- *biological ponds without breeding* (multi-stage or serial) - effluents, after preliminary settling, are sent to the pond without dilution with clean water. Ponds without breeding are arranged in 4-5 stages (the area of individual ponds of each stage is 2-2.5 hectares), which water passes through sequentially. The level of water purity gradually increases with each subsequent level. Duration of stay of water - up to 30 days;
- *biological ponds for further purification* sewage - have 2-3 (inflow of treated sewage) or 4-5 degrees (inflow of settled sewage). They are used when there is a need for increased quality of wastewater treatment and their additional treatment after artificial treatment facilities.

There are ponds with natural and artificial aeration, which accelerates water purification processes. The depth of ponds with natural surface aeration, as a rule, does not exceed 1.5 m. Artificial aeration with the help of mechanical aerators or by blowing air through the water column allows you to increase the depth of the pond to 3 m.

According to the presence of the discharge of purified water on the terrain or into water bodies, sewage-free and sewage biological reservoirs are distinguished. According to the method of operation, bioponds are divided into accumulative, contact, flow-through, and filtration-evaporation reservoirs. According to the discharge load on the surface area, biological ponds are divided into low loading (BOD_5 up to 50 kg/ha per day.), with normal loading (BOD_5 from 50 to 150 kg/ha per day.) and high loading (BOD_5 over 180 kg/ha per day).

The following types of bioponds are known:

and) aerobic-anaerobic for biochemical treatment of wastewater contaminated with organic impurities and production of biogas (Fig. 1)

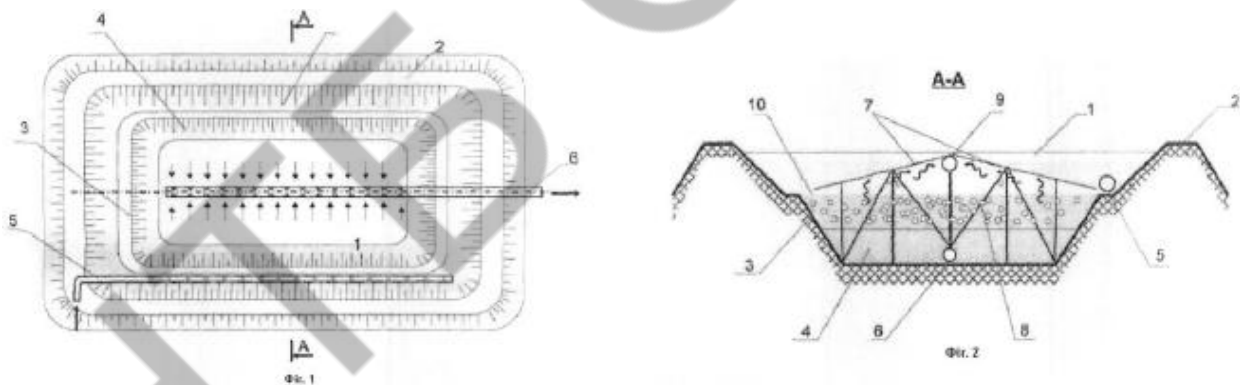

Fig. 1. Aerobic-anaerobic biopond for biochemical treatment of wastewater contaminated with organic impurities and production of biogas

Aerobic-anaerobic biopond for biochemical treatment of wastewater contaminated with organic impurities and production of biogas, in which organic substances in suspension are destroyed by bacteria in both aerobic and anaerobic conditions and further settle and decompose at the bottom in the anaerobic zone, releasing inorganic substances and compounds in the form of biogas, which is characterized by the fact that the lower part of the biopond is recessed for the formation of an anaerobic zone and is covered with a film coating on top, which is located on supports, while a pipeline is laid in the anaerobic zone for the collection and removal of biogas [10].

b) a facility for wastewater treatment using higher aquatic plants (Fig.2)

A facility for wastewater treatment using higher aquatic plants, consisting of serially interconnected bioponds in which sections of higher aquatic plants are kept afloat, which is distinguished by the fact that the facility additionally has a biopond for primary settling of wastewater, between bioponds with a biopond with an area of higher aquatic plants planted on a bioplateau, consisting of a layer of sand and a layer of crushed stone, and the last biopond has an area of higher aquatic plants afloat and an area of plants planted on a bioplateau, and in a biopond placed after a biopond for the primary settling of wastewater, a section of broad-leaved cattail is kept on a float, in the next and last bioponds, lake mullein is planted on the bioplateau, and a section of marsh sedge is kept afloat in the last biopond [11].

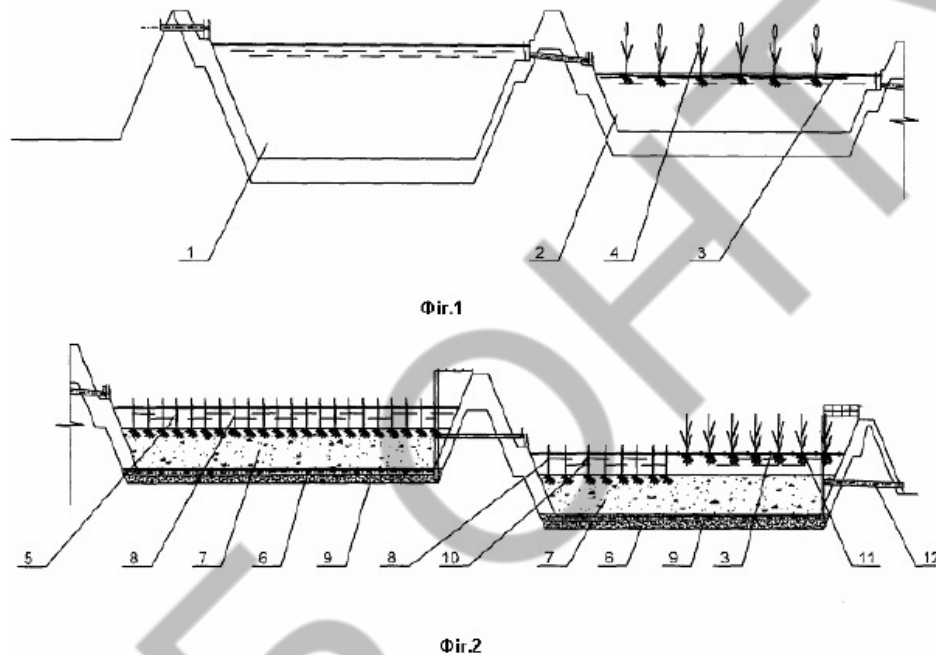

Fig. 2. A facility for wastewater treatment using higher aquatic plants

Contaminated wastewater enters biopond 1, where organic substances undergo coagulation under anaerobic conditions and settle to the bottom of biopond 1 in the form of flocs. After settling, the water flows by gravity from biopond 1 to biopond 2, where it passes through the root system of broad-leaved cattail 4, stems which are placed on biofence 3 and are not immersed in water. The branched root system of broad-leaved cattail 4 absorbs micro- and macroelements from the water washing it, and the formed biofilm on the roots and rhizomes oxidizes organic substances dissolved in water with the help of atomic oxygen, which is released by the plant through the root stomata.

In addition, in this biopond 2, the remains of suspended substances fall out and oxidation of organic substances takes place due to the saturation of water with oxygen and carbon, which was formed in biopond 1 in the process of anaerobic fermentation of pollutants that settled at the bottom of biopond 1. From biopond 2, water enters biopond 5, passes through the root system of the lake reed 6 and the loading zone 7, which consists of crushed stone, on which a fouling biofilm is also formed and it practically performs the functions of an additional biological filter. Next, the water

flows into biopond 8, in which the first half undergoes processes similar to those in biopond 5. In the second half of biopond 8, on biofence 3, marsh eider 11 is placed. Placing the marsh sedge 11 at the final stage of wastewater treatment makes it possible to disinfect the purified water from microorganisms and viruses and eliminate the allelopathic effect of the vegetation products of the sedge sedge 11 on the association of the lake sedge 8. The purified water is discharged through the collector 12 into a natural reservoir without chlorination. Larvae and eggs of helminths partially settle in bioponds 1, 2, and in bioponds 5 and 10 they are completely retained on the biofilm of crushed stone fouling 7. Passing water from top to bottom in bioponds 5 and 10 prevents leaching of loading from the ponds and forms an additional degree of purification in the formed biofilter on rubble 7 [11].

1.2. Bioplateau

Bioplateau is a man-made sewage treatment system that resembles bioponds. It is located in a cascade, and is built taking into account chemical and biological methods of cleaning.

If we classify the bioplateau from the point of view of engineering design, and at the same time take into account the hydraulic distribution of water flows, we will get the following categories:

- a) superficial;
- b) horizontal infiltration;
- c) vertical infiltration;
- d) bioplateau of mixed type [12].

Each type has its own characteristics and can clean different categories of wastewater.

Surface bioplats. The surface bioplate is similar to a "wetland landscape" created by nature, when the runoff is directed to the surface of the structure [13]. The difference from a natural sewage treatment plant is that the bioplateau has management systems that achieve high efficiency in wastewater treatment. Surface bioplats have the following advantages:

- small financial costs for the construction of the purifier;
- ease of management and low energy consumption.

But bioplateau also has disadvantages, namely:

- it is necessary to have large areas for the construction of the system;
- small hydraulic load, therefore - insufficiently high efficiency of wastewater treatment.

Oxygen is supplied to the surface biofields due to diffuse processes (through the root systems of plants). But this method of supplying oxygen cannot fully provide them with the needs of the bioplateau. In addition, the quality of wastewater treatment is affected by climate change. In the summer period, it is necessary to carry out sanitary measures to destroy mosquitoes.

Horizontal infiltration bioplateau. Such bioplateau are called horizontal because the effluents in the device move through the loading layers almost horizontally. The entire device consists of one or more sections. The sections have a waterproof coating, loading layers, and live plants and microorganisms [13].

Advantages of horizontal infiltration bioplates:

- high hydraulic loads are created in them;
- high efficiency of wastewater treatment for BOD and COD, suspended substances, as well as heavy metals;
- absence of an unpleasant smell on the territory of the bioplateau;
- absence of insects.

There is only one disadvantage of horizontal infiltration bioplateau - they remove nitrogen from sewage worse than vertical infiltration bioplateau.

Bioplates of the horizontal type are widely used in European countries, as well as in the USA, Australia and Japan.

Vertical infiltration bioplateau. In a bioplateau of a vertical type, runoff from the surface of the bioplateau falls vertically to the bottom. This structure is supplied with oxygen due to the diffusion of air from the atmosphere, as well as through the root systems of plants. Nitrification processes occur more intensively in vertical infiltration bioplateau than in horizontal ones. Therefore, it is better to use a vertical type bioplateau for cleaning sewage with a high level of nitrogen content [13].

Among the disadvantages of this wastewater treatment system, one should note the difficulty in managing the treatment process, as well as in the process of creating and maintaining favorable conditions for normal operation.

III. OBJECT, SUBJECT, AND METHODS OF RESEARCH

Object of study– the hydrological complex of the Bolshaya Almatynka River and Sayran Lake.

Subject of study – recreational properties of Lake Sayran.

Lake Sayran is an artificially created reservoir for recreational purposes in the center of the city of Almaty on the site of a former quarry for the extraction of sand and gravel materials. The lake is filled by the Bolshaya Almatynka River, which is formed by the confluence of three water streams of the frontal moraine of two powerful Zailiysky Alatau glaciers. The river is prone to mudslides, destructive mudslides sometimes pass along it, reaching the territory of the city. Today, the riverbed is reinforced and concreted, special concrete barriers are installed along the riverbed, which dampen the speed of water movement during the melting of mountain snow and ice. The area of the lake is 50 hectares, its maximum depth is 12-15 m. In the 1970s, the lake was a popular recreational facility for city residents due to the high quality of mountain water.

In 2022, an excess of the LCP indicator was found in Lake Sairan, which indicates fecal pollution caused by the discharge of untreated wastewater from domestic and industrial enterprises into the river, uncontrolled water pollution by household waste.

To date, there is a strong degradation of the recreational potential of Lake Sayran and the recreation area of the townspeople adjacent to it.

Research methods.The work used general scientific (analysis and synthesis) and special research methods. The theoretical and methodological basis of the research is a systematic approach.

When studying individual issues, the following methods were used: at the stage

of collecting, systematizing and processing information for conducting research - inductive, observation; in the process of theoretical understanding of the problem - deductive and graphical representation of data, as well as methods of analysis and synthesis to combine various components of environmental and economic phenomena in a single process; at the proposal development stage – modeling, grouping, generalization and comparison.

In our work, we used the hypothesis of the possibility of seasonal restoration of the recreational quality of Lake Sayran when using the bioplateau technology. Seasonal cleaning on the bioplateau will eliminate the possibility of consequences from possible emergency situations related to the mountainous origin of the Bolshaya Almatynka River. It should be noted that even a non-working bioplat will have greater aesthetic appeal for city residents.

IV. RESULTS

The ability of higher aquatic plants to purify water has been known for a long time and residents ancient settlements tried to take drinking water from rivers in areas located below massifs of thickets of aquatic vegetation.

Analyzing the biotic component of the river ecosystem, it can be seen that thickets of higher aquatic vegetation develop along the banks of the river, mainly in the places of beam exits, behind which the polluted surface runoff from the catchment area flows into the river. In ponds, lakes and reservoirs, higher aquatic vegetation develops intensively in the most polluted areas of the water body.

This is due to the fact that wastewater from settlements, surface runoff for the development of territories contain organic substances, nitrogen and phosphorus, which are nutrients for plants. Biogenic elements are used by higher algae for their growth and development, and organic substances are subject to bacterial destruction by the periphyton film that develops on the underwater part of plants.

Phytotechnology is a method of cleaning polluted natural and wastewater, based on the use of processes of natural self-cleaning of water bodies, using higher aquatic vegetation, aquatic microflora and microorganisms, which has become widespread in the countries of Western Europe (Great Britain, Denmark, Switzerland, Finland, Spain, France, Germany, Norway, Austria, Estonia), as well as in America, Canada, New Zealand.

The use of phytotechnology is most suitable for the treatment of household wastewater in small settlements, detached houses, schools, sanatoriums, camping sites and other places of public recreation. Phytotechnologies can also be used for the treatment of surface runoff from agricultural lands, built-up areas and industrial sites, collector drainage, quarry and mine waters, wastewater from animal husbandry complexes, leachate from landfills of solid household waste, in the treatment of industrial wastewater and its mixture with household wastewater with water, phytotechnology is used as additional purification.

Such engineering structures as the bioplateau are the most advanced methods of natural biological wastewater treatment, which are widely used in the world [14].

Bioplateau– an efficient, ecological and economic construction for the treatment of various categories of wastewater. The main idea of the technology is to use natural

elements of river protection against pollution and water purification, which use solar energy for their operation and do not require maintenance. These elements primarily include higher aquatic vegetation: reeds, reeds, sedges, reeds, rushes, and many others.

The idea of using higher aquatic plants for wastewater and natural water purification by creating stationary and floating devices was first put forward in Ukraine by the author together with Professor, Doctor of Biological Sciences O.P. Oksiyuk in 1977 [15] and the facilities implementing them were called "bioplateau".

The term "phytotechnology" was proposed and substantiated by UNEP to define similar technological solutions based on the principle of using higher aquatic plants [16].

The main idea of phytotechnology facilities is to filter wastewater through thickets of higher aquatic plants and a specially selected sand-gravel filter with preliminary sedimentation of suspended particles in a sedimentation tank.

The two types of structures differ fundamentally, the schemes of which are shown on Fig. 3.

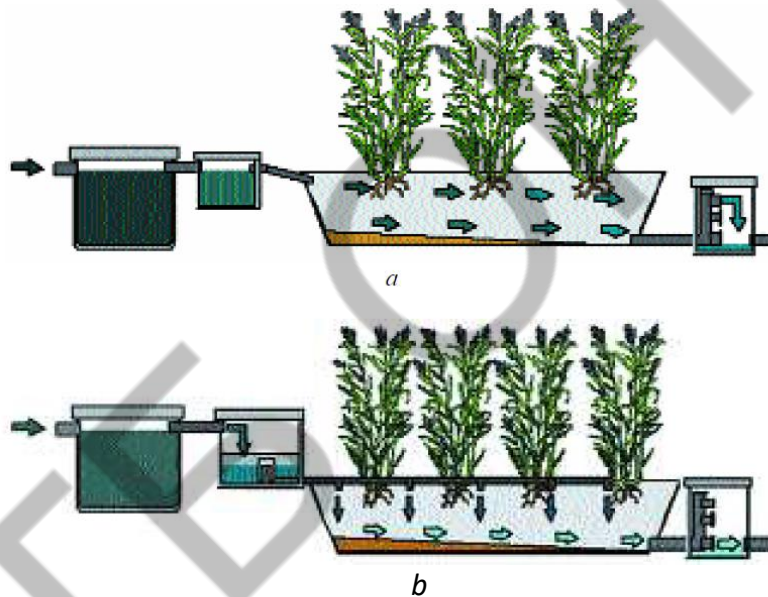

Fig. 3. Schematic diagram of phytotechnology facilities:
 a – with horizontal filtering; b - with vertical filtering

The construction of phytotechnology structures is extremely simple, is carried out from local materials and does not require either qualified labor, special mechanisms, expensive materials and devices.

Below are the main stages of the construction of a bioplateau: creating a pit, pouring a sand cushion under an anti-filtration film and laying it to protect groundwater from sewage pollution (Fig. 4, a), the formation of a sand-gravel filter with a wastewater distribution system (Fig. 4, b) and planting higher aquatic vegetation (Fig. 4, c).

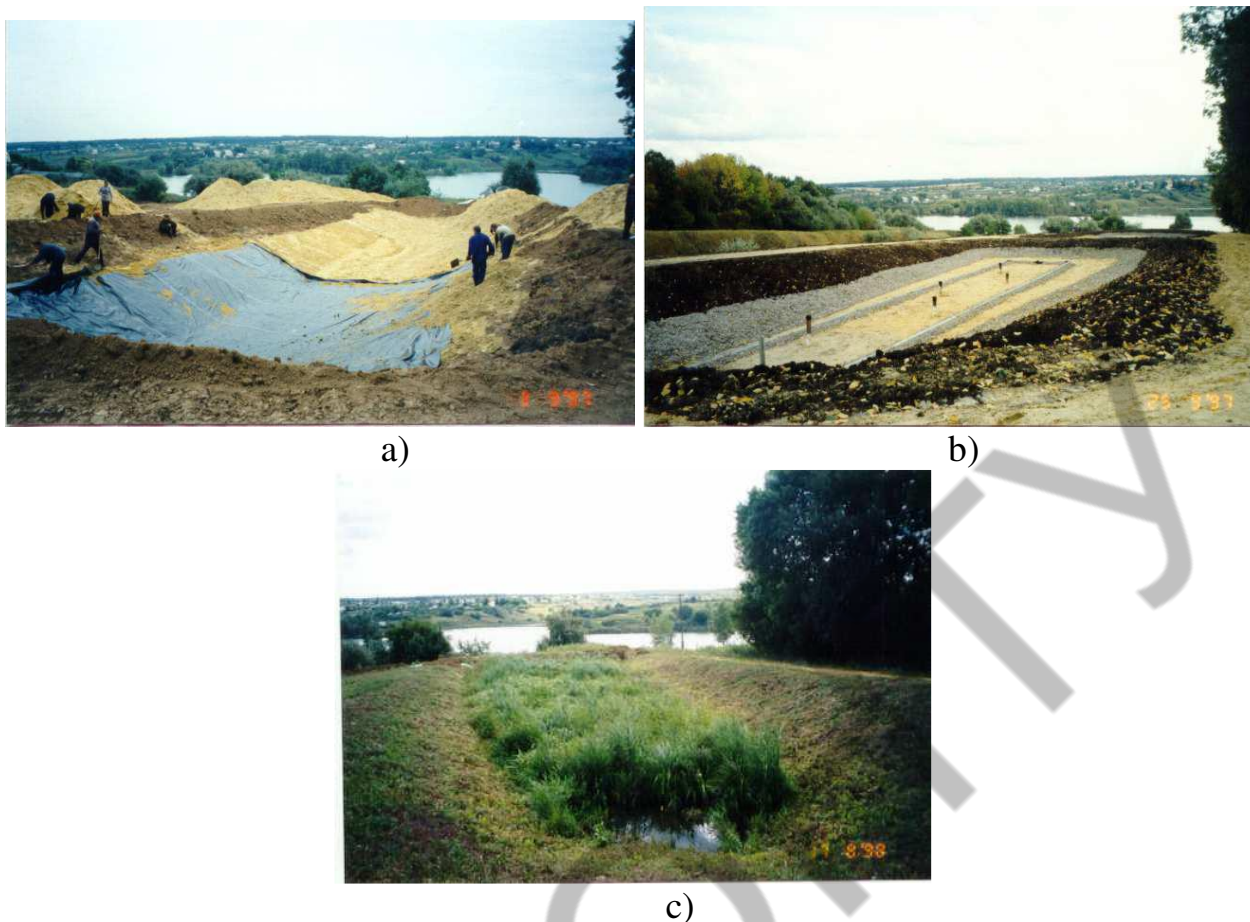

Fig. 4. Construction stages of the phytotechnology facility in the village of Velyki Prokhody in the Kharkiv region

The type of higher aquatic vegetation that dominates in this area is usually used. Planting is carried out with the help of a rhizome-soil mass, which is excavated by a mechanized method on the coastal areas of the adjacent water body, transported to the place of laying and distributed on the prepared surface of the structure being created.

The system of phytotechnology structures was successfully applied in Ukraine for de-eutrophication of water coming from the Dniprodzerzhyn reservoir on the Dnipro-Donbas canal to Donetsk and Kharkiv. Anti-plankton protection of the main water intake of the canal and a system of coastal and channel bioplateau on the water transportation route were used here [17].

A high purification capacity of phytotechnology facilities has been established, which is not inferior in its efficiency to expensive traditional treatment facilities [14].

Numerous long-term field observations at existing facilities (bioplateau) in different countries established [14] that the efficiency of wastewater treatment according to the following water quality indicators is:

- Suspended substances - 90-95%;
- Organic substances according to BOD content - 95-98%;
- Nitrogen and phosphorus - 50-70%;
- Bacteriological contamination - 99-99.5%.

As you can see, a sufficiently high level of wastewater treatment has been established by various studies of existing facilities. At the same time, the oxygen content increases significantly due to photosynthetic aeration of water.

The technology of wastewater treatment using bioplates has certain advantages and disadvantages compared to traditional municipal wastewater treatment facilities.

The main disadvantage of phytotechnologies is the need for large areas compared to mechanical and chemical-biological treatment facilities, which are usually located on small sites. Therefore, phytotechnology facilities are recommended for pollution sources located in rural areas, where the necessary territorial opportunities usually exist.

The main advantages of phytotechnology are low cost, no need for electricity, ease of construction, and practically no need to maintain operating personnel.

Aquatic plants in reservoirs perform the following main functions:

- filtration (contribute to sedimentation of suspended substances);
- absorptive (absorption of biogenic elements and some organic substances);
- accumulative (the ability to accumulate some metals and organic substances that are difficult to decompose);
- oxidative (in the process of photosynthesis, water is enriched with oxygen);
- detoxification (plants are able to accumulate toxic substances and transform them into non-toxic ones).

When cleaning wastewater, the most common types of higher aquatic plants are used, such as reeds, lake reeds, narrow-leaved and broad-leaved rushes, combed and curly sedum, spirodella, elodea, water hyacinth (*Eichhornia*), yellow cockscombs, sedum, common arrowroot, buckwheat, sea sedge, urut, hara, iris, etc.

The ability of higher aquatic plants to remove pollutants from water - biogenic elements (nitrogen, phosphorus, potassium, calcium, magnesium, manganese, sulfur), heavy metals (cadmium, copper, lead, zinc), phenols, sulfates - and reduce its pollution by oil products, synthetic surface-active substances, controlled by indicators of organic pollution of the environment, such as BOD and COD, allowed their use in the practice of cleaning industrial, economic and domestic wastewater and surface runoff both in Ukraine and around the world.

Low-cost technologies of "Bioplateau" were developed and implemented by Ukrainian specialists in various countries of the world, such as Germany (city of Wisinburg), Syria (city of Aleko, textile factory "Judy"), Russia (the village of Shongo, Murmansk Region). In Ukraine, the use of higher aquatic plants on various types of bioplateau - engineering-biological structures that provide cleaning and re-treatment of household and industrial wastewater and polluted surface runoff, which do not require (or almost do not require) the consumption of electricity and the use of chemical reagents with minor periodic operational maintenance - started in the last century.

The Institute of Hydrobiology of the National Academy of Sciences, Kyiv, proposed and investigated the use of bioplateau as a water treatment facility in the channels through which water is transported from the Dnipro for the water supply of such regions as the Crimea, Donbas, as well as in other industries. Extensive study and implementation of bioengineering structures using higher aquatic plants is carried out at the Institute of Ecological Problems, Kharkiv. In 2003, at the initiative of the

Ministry of Ecology and Natural Resources of Ukraine, the National Academy of Urban Economy developed a program for the introduction of phytotechnology in Ukraine for 2005-2015.

In 2004, on the initiative of the Kharkiv regional administration, a similar program for the introduction of phytotechnology was developed.

Bioplateau structures were designed and implemented in Donetsk region, Zaporizhzhia region (Mokryansky quarry), Luhansk region (Krasnorichenske village, Parkhomenko village, Ivanivka village), Kharkiv region (Vilshany, Protopopiovka, Solonytsivka, Martova villages) , Borivske, Zolochiv, in the Kharkiv State Zoological Park).

Thus, on the basis of the conducted research, it is proposed:

- cleaning should be carried out only during the bathing season, which will eliminate the possibility of destruction of hydrotechnical structures due to possible changes in the regime of the Bolshaya Almatynka River;

- to create a bio-plateau next to Lake Sayran, to improve its recreational quality. The creation of a bioplateau also involves the creation of a dam for impregnation of water on the bioplateau (Fig. 8). The dam is proposed to be placed at the confluence of the Bolshaya Almatynka River into Lake Sayran.



Fig. 8. Bioplateau project on Lake Sayran

- to create bioplats next to the Bolshaya Almatynka river for seasonal water purification in it. For water supply, it is planned to create two dams for the Pocha of water on the bioplateau (Fig. 9). Bioplateau is planned to be placed in the Park of the First President.

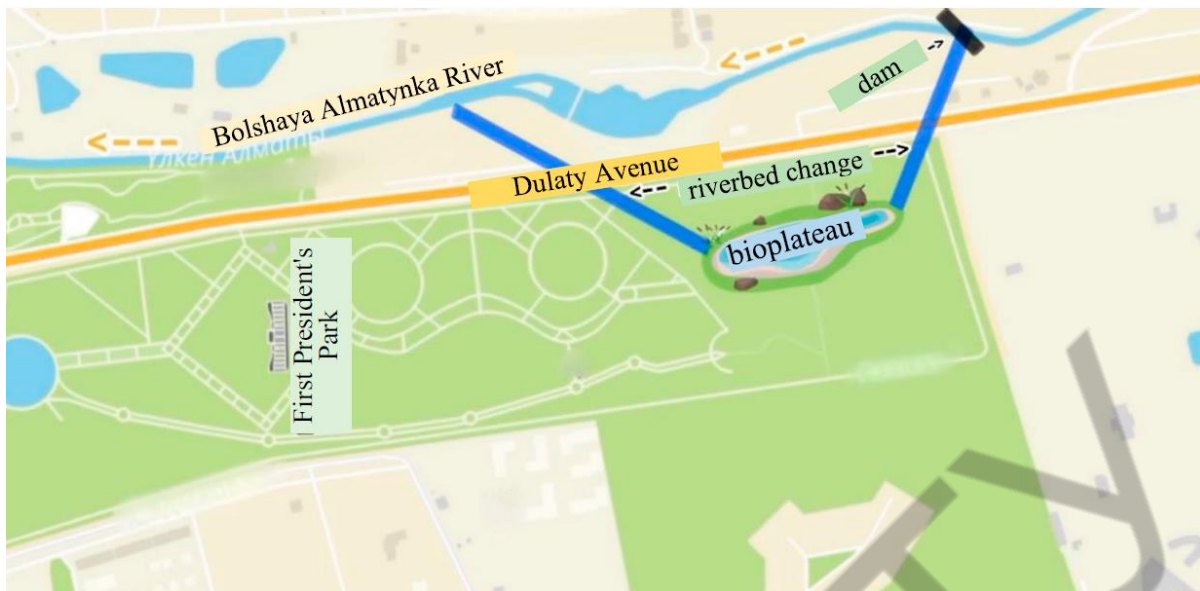

Fig. 9. Bioplateau project on the Bolshaya Almatynka River

This project envisages maintaining the physico-chemical parameters of water in Lake Sayran not lower than the third quality class.

The proposed technology has the following advantages:

- bioplateau technology is environmentally friendly and simulates the natural processes of self-purification of water;
- bioplateau during its construction is much cheaper than traditional sewage treatment plants and has low operating costs;
- the technology does not involve the use of coagulants, flocculants, ionoactive compounds, artificially cultivated strains of microorganisms-destroyers, as well as forced aeration of wastewater;
- bioplateau technology is characterized by ease of construction and reliability of operation. The service life of treatment facilities without major repairs is 20 - 25 years;
- bioplateau ensures stable efficiency of wastewater treatment both in summer and in winter;
- the maintenance staff of the wastewater treatment plant complex consists of one employee who periodically inspects the facilities, organizes the cleaning of the sedimentation tank and prepares it for work in the winter period;
- if there are swampy areas of the area, it is possible to include them in the composition of treatment facilities, which significantly reduce the cost of construction and contribute to the rational use of land resources;
- the higher aquatic vegetation on the surface of the bioplateau blocks provides deodorization of domestic wastewater, therefore the size of the sanitary protection zone of the complex of bioplateau treatment facilities can be up to 50m [14].

V.CONCLUSIONS

The results of the work allow us to draw the following conclusions:

- in view of the complex hydrological regime of the Bolshaya Almatynka River, it is advisable to carry out cleaning measures seasonally during the recreational

use of Lake Sayran;

- the proposed hydrotechnical structures (dams and bioplateau), provided they are properly designed, are able to improve the recreational potential of recreation areas in the city of Almaty;
- the use of bioplateau is a low-cost and effective way of water purification in the Bolshaya Almatynka River and Lake Sayran;
- the proposed use of bioplateau will allow support the chemical parameters of the water in Sayran Lake are not lower than the third quality class and to significantly improve the water quality in the Bolshaya Almatynka River.

VI. REFERENCES

1. Stolberg, F.V., Ladyzhensky, V. N., Vergeles, Y. I., Ishchenko, A. V., Khudyakov, A. A. (2002). The use of bioplateau treatment facilities for the treatment of urban wastewater. Scientific and Technical Collection, 36, 182-185.
2. Karelin, Ya. A. (1986) Wastewater treatment in biological ponds. Stroyizdat.
3. Ostroumov, S. A. (2005) Self-purification of water in nature: Mechanism of natural cleaning of water ecosystems, factors and processes affecting self-cleaning. Ecology and life, 7, 42-47.
4. Ozimek, T., Renman, G. (1995) Wykorzystanie makrofitów w niekonwencjonalnych pozyskaniach ścieków. Wiadomości Ekologiczne, 41 (4), 239-254.
5. Kowalik, P. (1997) Oczyszczalnie hydrofitowe w Polsce. Materiał z IX Ogólnopolskiej konf. nauk.-techn. problemy gospodarki wodno-ściekowej w regionach rolniczo-przemysłowych, 32-44.
6. Krot, Y. G. (2006) The use of higher aquatic plants in biotechnologies of surface and wastewater treatment. Hydrobiological magazine, 42 (1), 47-57.
7. Mochalov, I.P., Rodziller, I.D., Zhuk, E.D. (1991) Cleaning and disinfection of wastewater of small settlements. Stroyizdat.
8. Nenasheva, M.N., Dobrynina, L.F., Sharypova, T.F. (2002) Scientific concept of creation of "new type" treatment facilities for wastewater treatment in small settlements. Bulletin of OGU, 3, 21-24.
9. Shirokov, V. M., Kirvel, I. I. (1987) Ponds of Belarus. Urajai.
10. Sherenkov, I. A., Nesterenko, O. V. (2011) Aerobic-anaerobic biopond for biochemical treatment of wastewater contaminated with organic impurities and production of biogas. Patent database of Ukraine. <http://uapatents.com/2-93112-aerobno-anaerobnijj-biostavok-dlya-biokhimichnogo-ochishhennya-zabrudnenikh-organichnimi-domishkami-stichnikh-vod-ta-oderzhannya-biogazu.html>
11. Livshyts, M. N., Shapoval, O. Y., Hryshchenko, N. V., Prushansky, M. Y., Kravets, V. V., Maslov, V. M., Petruk, V. V. (2004) Device for wastewater treatment using higher aquatic plants. Patent database of Ukraine. <http://uapatents.com/3-3377-sporuda-dlya-ochishhennya-stichnikh-vod-z-vikoristannyam-vishhikh-vodyanikh-roslin.html>.
12. Bioplate for wastewater treatment and their classification. PROMSTOK https://www.promstok.com/articles/ochistnye-sooruzheniya/bioplateau_dlya_ochistki_stochnykh_vod_i_ikh_klassifikatsiya/.
13. Ladyzhenskyi, V.N., Saratov, I.E. (2004) Protection of water objects from surface runoff pollution from the territory of landfill sites. <https://waste.ua/cooperation/2004/thesis/ladishenskiy.html>.
14. Stolberg, F. V. Low-cost technologies for ecological restoration of small rivers of Ukraine. Scientific and technical collection. 99. 253-266. https://eprints.kname.edu.ua/21751/1/253-266_Stolberg_ФВ.pdf.
15. Okysiuk, O.P., Stolberg, F.V. (1988) Control of water quality in canals. Nauk.dumka.
16. UNEP Standard (2000) Phytotechnology and Ecotechnology. Manual for designing, constructing and operating.
17. Okysiuk, O.P., Stolberg, F.V. (1990) Assessment of the impact of hydrotechnical construction on water quality. Nauk. dumka.

DEVELOPMENT OF A PLANT FOR THE MANUFACTURE OF WEARRESISTANT PARTS OF MINING EQUIPMENT Authors: Fihol Artem, Dorozhynskyi Serhii Advisor: Vakhonina Larysa Mykolayiv National Agrarian University (Ukraine).....	751
OPTIMIZATION OF THE LOCAL MARINE ENERGY SYSTEM WITH DIESEL-GENERATORS Authors: Daria Pluzhnyk, Bohdan Lisovyk Advisor: Halyna Bielokha National Technical University of Ukraine «Igor Sikorsky Kyiv Polytechnic Institute» (Ukraine)...	773
DETERMINATION OF WAYS OF PROTECTING CRITICAL OBJECTS OF THE ENERGY COMPLEX AGAINST AIR STRIKES THROUGH THE JOINT APPLICATION OF DIFFERENT FORCES AND MEANS Author: Andrii Soliakov Advisor: Andrii Volkov Ivan Kozhedub Kharkiv National Air Force University (Ukraine).....	783
5. ECOLOGY AND ENVIRONMENTAL PROTECTION.....	797
ECOLOGICAL ASSESSMENT OF THE TERRITORIAL COMPLEXES OF TATARBUNARS' KYI DISTRICT OF ODESSA REGION Author: Iryna Voynyts'ka ¹ Advisors: Mariia Madani ¹ , Mahmud Ladjel ² ¹ Odesa National Technological University (Ukraine) ² Université de Bejaia (Algeria).....	798
BIOPLATEAU AS A SYSTEM FOR IMPROVING THE WATER QUALITY OF SAYRAN LAKE Author: Lyalya Timurova ¹ , Anastasiya Shmikova ² Advisor: Mikhail Katkov ¹ , Roman Shevchenko ² ¹ Kazakh National Research Technical University named after KI Satbayev (Kazakhstan) ² Odesa National University of Technology (Ukraine).....	811
TREATMENT OF FILTRATES OF LANDFILLS BY BIOLOGICAL METHOD Authors: Khrystyna Malychkovych ¹ , Nino Lomanidze ² , Bekkhan Umarashvili ³ Advisor: Myroslav Malovanyy ¹ , Magda Davitashvili ³ ¹ Lviv Polytechnic National University (Ukraine) ² Akaki Tsereteli State University (Georgia) ³ Iakob Gogebashvili Telavi State University (Georgia).....	825
INNOVATIVE TECHNOLOGIES FOR THE DISPOSAL OF SEDIMENTS FORMED AT TREATMENT PLANTS IN UKRAINE AND POLAND Authors: Anastasiia Maksymiuk ¹ , Krzysztof Dach ² Advisor: Myroslav Malovanyy ¹ ¹ Lviv Polytechnic National University (Ukraine) ² Rzeszow University of Technology (Poland).....	833
ANALYSIS OF BIOLOGICAL METHODS OF WASTEWATER TREATMENT Authors: Maksym Danyliuk ¹ , Dilian Georgiev ² Advisor: Ivan Tymchuk ¹ ¹ Lviv Polytechnic National University (Ukraine) ² Technical University – Varna (Bulgaria).....	847