

Ministry of Education and Science of Ukraine
Black Sea Universities Network

ODESA NATIONAL UNIVERSITY OF TECHNOLOGY

International Competition of
Student Scientific Works

BLACK SEA SCIENCE 2022 PROCEEDINGS



ODESA, ONUT 2022

Ministry of Education and Science of Ukraine

Black Sea Universities Network

Odesa National University of Technology

International Competition of Student Scientific Works

BLACK SEA SCIENCE 2022

Proceedings

Odesa, ONUT 2022

Editorial board:

Prof. B. Iegorov, D.Sc., Professor, Rector of the Odesa National University of Technology, Editor-in-chief

Prof. M. Mardar, D.Sc., Professor, Vice-Rector for Scientific and Pedagogical Work and International Relations, Editor-in-chief

Dr. I. Solonytska, Ph.D., Associate Professor, Director of the M.V. Lomonosov Technological Institute of Food Industry, Head of the jury of «Food Science and Technologies»

Dr. Yu. Melnyk, D.Sc., Associate Professor, Director of the G.E. Weinstein Institute of Applied Economics and Management, Head of the jury of «Economics and Administration»

Dr. S. Kotlyk, Ph.D., Associate Professor, Director of the P.M. Platonov Educational-Scientific Institute of Computer Systems and Technologies “Industry 4.0”, Head of the jury of «Information Technologies, Automation and Robotics»

Prof. O. Titlov, D.Sc., Professor, Head of the Department of Oil and Gas Technologies, Engineering and Heat Power Engineering, Head of the jury of «Power Engineering and Energy Efficiency»

Prof. G. Krusir, D.Sc., Professor, Head of the Department of Ecology and Environmental Protection Technologies, Head of the jury of «Ecology and Environmental Protection»

Dr. V. Kozhevnikova, Ph.D., Associate Professor, of the Department of Hotel and Catering Business, Technical Editor

Black Sea Science 2022: Proceedings of the International Competition of Student Scientific Works / Odesa National University of Technology; B. Iegorov, M. Mardar (editors-in-chief) [*et al.*]. – Odesa: ONUT, 2022. – 749 p.

Proceedings of International Competition of Student Scientific Works «Black Sea Science 2022» contain the works of winners of the competition.

The author of the work is responsible for the accuracy of the information.

Organizing committee:

Prof. Bogdan Iegorov, D.Sc., Rector of Odesa National University of Technology, Head of the Committee

Prof. Maryna Mardar, D.Sc., Vice-Rector for Scientific and Pedagogical Work and International Relations of Odesa National University of Technology, Deputy Head of the Committee

Prof. Baurzhan Nurakhmetov, D.Sc., First Vice-Rector of Almaty Technological University (Kazakhstan)

Prof. Michael Zinigrad, D.Sc., Rector of Ariel University (Israel)

Prof. Plamen Kangalov, Ph.D., Vice-Rector for Academic Affairs of “Angel Kanchev” University of Ruse (Bulgaria)

Prof. Heinz Leuenberger, Ph.D., Professor of the Institute of Ecopreneurship of University of Applied Sciences and Arts (Switzerland)

Prof. Edward Pospiech, Dr. habil., Professor of the Institute of Meat Technology of Poznan University of Life Sciences (Poland)

Prof. Lali Elanidze, Ph.D., Professor of the Faculty of Agrarian Sciences of Iakob Gogebashvili Telavi State University (Georgia)

Dr. Dan-Marius Voicilas, Ph.D., Associate Professor of the Institute of Agrarian Economics of Romanian Academy (Romania)

Prof. Stefan Dragoev, D.Sc., Vice-Rector for Scientific Work and Business Partnerships of University of Food Technologies (Bulgaria)

Prof. Jacek Wrobel, Dr. habil., Rector of West Pomeranian University of Technology (Poland)

Dr. Mei Lehe, Ph.D., Vice-President of Ningbo Institute of Technology, Zhejiang University (China)

Dr. V. Kozhevnikova, Ph.D., Associate Professor of the Department of Hotel and Catering Business of Odesa National University of Technology, Secretary of the Committee

INTRODUCTION

International Competition of Student Scientific Works “Black Sea Science” has been held annually since 2018 at the initiative of Odesa National University of Technology (formerly Odesa National Academy of Food Technologies) with the support of the Ministry of Education and Science of Ukraine. It has been supported by Black Sea Universities Network (the Association of 110 higher education institutions from 12 countries of the Black Sea Region) since 2019, and by Iseki-FOOD Association (European Integrating Food Science and Engineering Knowledge into the Food Chain Association) since 2020.

The goal of the competition is to expand international relations and attract students to research activities. It is held in the following fields:

- Food science and technologies
- Economics and administration
- Information technologies, automation and robotics
- Power engineering and energy efficiency
- Ecology and environmental protection

The jury includes both Ukrainian and foreign scientists. In the 4 years that the competition has been held, the jury included scientists from universities of 24 countries: Angola, Azerbaijan, Benin, Bulgaria, China, Czech Republic, France, Georgia, Germany, Greece, Israel, Italy, Kazakhstan, Latvia, Lithuania, Moldova, Pakistan, Poland, Romania, Serbia, Slovakia, Switzerland, Turkey, USA.

At the same time, every year the geography has expanded and the number of foreign jury members has increased: from 46 jury members representing 25 universities from 12 countries in 2018, to 73 jury members of the 46 universities from 19 countries in 2022.

More than a thousand student research papers have been submitted to the competition from both Ukrainian and foreign institutions from 25 countries: China, Poland, Mexico, USA, France, Greece, Germany, Canada, Costa Rica, Brazil, India, Pakistan, Israel, Macedonia, Lithuania, Latvia, Slovakia, Romania, Kyrgyzstan, Kazakhstan, Bulgaria, Moldova, Georgia, Turkey, Serbia.

The interest of foreign students in the competition grew every year. In 2018, the students representing 15 institutions from 7 countries have submitted 33 works. In 2021 the number of submitted works increased to 73, authored by the students of 40 institutions from 18 countries.

The competition is held in two stages. In the first stage, student research papers are reviewed by members of the jury who are experts in the relevant fields. In the second stage of the competition, the winners of the first stage have the opportunity to present their work to a wide audience in person or online.

All participants of the competition and their scientific supervisors are awarded appropriate certificates, and the scientific works of the winners are included in the electronic proceedings of the competition. Every year the competition receives a large number of positive responses from Ukrainian and foreign colleagues with the desire to participate in the coming years.

4. POWER ENGINEERING **AND ENERGY EFFICIENCY**

IMPROVEMENT OF THE REFRIGERATION SYSTEM WITH RADIATIVE COOLING AND COMBINED CONDENSATION

Author: Aleshchenko Mikhail

Advisor: Tsoy Alexander
Almaty Technological University (Kazakhstan)

***Abstract.** In this paper I will describe how, for what purposes and what is the most effective way to use solar radiation. As well as I will report all data on the benefits, harms and costs of this project. This paper will provide evidence of the effectiveness of the project, practical calculations and application in a real environment. In addition to all this, I will show you schematics of working installations. I will explain, show and tell you everything*

***Keywords:** Radiation cooling, condensers, freons, table data, installation diagrams*

1. Introduction.

Greetings colleagues. Due to the deplorable state of the environment and the significant shortage of resources and electricity, we propose a system by which refrigeration chambers can be cooled by means of renewable energy sources, namely by means of solar radiation

Radiation cooling: Lowering the temperature of the earth's surface and objects by means of thermal radiation (i.e. temperature or thermal radiation) in the ultraviolet, visible, and infrared wavelength ranges. It is realized, as a rule, in quiet clear nights in the absence of other significant heat exchange processes in the atmosphere (turbulent heat transfer, heat exchange of water phase transitions) and in the absence (or lack in the daytime hours in winter) of solar radiation inflow. At the same time, the expenditure part of the radiation balance of the atmosphere - radiation of the Earth's surface (objects) and the atmosphere itself - becomes the prevailing value in this balance and leads to the fact that the temperature of the surfaces of objects on the ground and the ground drops below the temperature of the nearby layer of ambient air.

2. Selection of the main possible scenarios of application of refrigeration systems

Considering the uses of radiation cooling, the following classification of refrigeration systems can be proposed:

- 1) By cooled substance:
 - a) with a liquid coolant used directly for heat removal;
 - b) with a liquid coolant used for removal of condensation heat
 - c) with refrigerant;
 - d) using air as the heat transfer medium.

Figure 1 shows an example of a cooling system in which radiation cooling is used to cool the intermediate coolant, and further use it to lower the temperature of the cooled object. The disadvantage of such systems is the high cost of the system, due to the large amount of coolant in the system, a large accumulator of cold.

If the radiation cooling is not enough for cooling to the desired temperature, the cold accumulator can also store the cold created by the chiller, or it is possible to use the chiller to cool the room directly [21].

An example of a refrigeration system in which the RO is used to condense the refrigerant in the intermediate condenser of a refrigeration machine and perform a cycle with natural circulation is shown in Fig. 3.

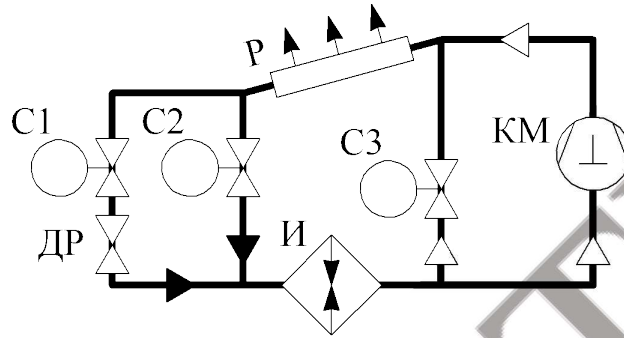

DR - throttling device; I - evaporator; R - radiator;
C1...C3 - solenoid valves; KM - compressor

Fig. 3 - Scheme of refrigeration system with natural circulation of the refrigerant due to radiation cooling

In this case, it is proposed to refuse a separate circuit of coolant circulation and cool directly in the radiator of the refrigerant.

Systems for air conditioning, in which the cooled air circulates directly through the radiator have disadvantages: high metal intensity of radiators, significant volumes of air ducts, large occupied areas, because the heat transfer from the air flow is much less than from the liquid flow. In this case, in such systems there is no risk of loss of coolant, they are the most simple and reliable.

According to the method of circulation of the coolant can be distinguished systems:

- 1) With forced circulation, as a result of pumping by a pump, compressor or fan;
- 2) With natural circulation, as a result of natural convection due to temperature differences.

According to the priority of the cooling method, it is possible to divide systems in which:

- 1) RO is used as the main source of cooling;
- 2) RO is an additional source of cold to the main refrigeration machine.

Classification of methods of application of refrigeration supply systems with the use of RH, the main of which are: air conditioning, refrigeration of fruit and vegetable storages; storage of refrigerated products.

Table 1 with a comparison of refrigeration systems and methods of their application is compiled.

Table 1 - Comparison of refrigeration systems

No	Reference	System name	Cold accumulator	Circulation of the working substance	Area of application
1	[22]	Refrigeration system with pumped circulation of coolant through radiators with cold accumulator	Yes	Pumping	Water cooling
2	[23]	System of natural water circulation through the panel in the form of a thermosiphon	Yes	Natural	Water cooling
3	[21]	Hybrid air conditioning system using phase transition materials	Yes	Pumping	Air conditioning and heating
4	[24]	Cooling system with air circulation in a duct heat exchanger	No	By fan	Air Conditioning
5	[25]	Cooling system with open water circulation circuit	Yes	Pumping	Water cooling
6	[26]	Refrigeration system with pumped circulation of coolant through radiators (three different designs)	Yes	Pumping	Air Conditioning
7	[27]	Refrigeration system with pumped circulation of coolant through polyphenylene oxide resin radiators	Yes	Pumping	Air Conditioning
8	[28]	Daytime radiation cooling system using spectral-selective surfaces	No	Natural	Air Conditioning
9	[15]	Refrigeration system with pumped circulation of coolant through radiators, cold accumulator for cooling condenser of refrigeration machine	Yes	Pumping	Refrigeration machine condenser cooling
10	[29]	Daytime cooling system, with pumped water circulation through radiators	Yes	Pumping	Air conditioning, getting cold water

Modeling of operation of the refrigeration system with condensation heat removal

The climate of Kazakhstan is continental. Here, in many regions, daytime atmospheric air temperatures can reach 35°C and higher in summer. In southern and western regions, given the influence of solar radiation, surface air temperature can regularly rise to 40 ... 45 ° C. Such high temperatures may affect the operation of steam-compression refrigeration machines with air-cooled condensers [30]. In them, in the

daytime, the condensation temperature can rise up to 55 ... 60°C. Such a high condensation temperature reaches the limit value for the existing models of compressors. As a result, the refrigeration machines can be switched off by the safety automatics or will work in inadmissible temperature modes, which will reduce their service life. Also in these conditions, refrigeration machines consume a relatively large amount of electricity.

In this connection, the urgent task is to find ways to reduce condensation temperature. Traditionally, evaporative condensers or condensers with adiabatic cooling of incoming air flow are used to solve the above task. However, both of these solutions require an additional constant flow of clean fresh water. In many regions fresh water can be a scarce resource [31]. Given the unfavorable forecast of reduction of available fresh water in Kazakhstan in the next decades [32], the use of fresh water for cooling condensers of refrigeration machines cannot be a recommended universal solution. In this connection it is necessary to consider other ways of condensation temperature reduction without use of fresh water.

In this section of the paper the use of radiation cooling for condensation heat removal is investigated. Radiation cooling can be used at night to create a reserve of cooled coolant. This coolant in the daytime at hours with the highest atmospheric air temperature is directed to the condenser, where it takes the condensation heat of the steam-compression refrigeration machine. In this case, it can be used to remove all of the condensation heat or only part of it. This reduces the condensation temperature and the energy consumption of the compressor.

Since the coolant (fresh water) will circulate through a closed hydraulic circuit, its losses during the annual operating cycle of the refrigeration system will be negligible.

Objective: to investigate the possibility of using radiation cooling for removal of condensation heat of a steam-compression refrigeration machine.

Objectives:

- 1) To develop a technical and economic mathematical model of refrigeration system with condensation heat removal;
- 2) To determine optimal parameters of refrigeration system having the shortest payback period.

Subject of research possesses novelty, as previously only general principle schemes of systems of this type were presented without their detailed research [15].

3.1 Principle diagram under study

Figure 4 shows a schematic diagram of a refrigeration system in which the condensation heat of a steam-compression refrigeration machine (SCRM) is removed at the expense of radiation cooling.

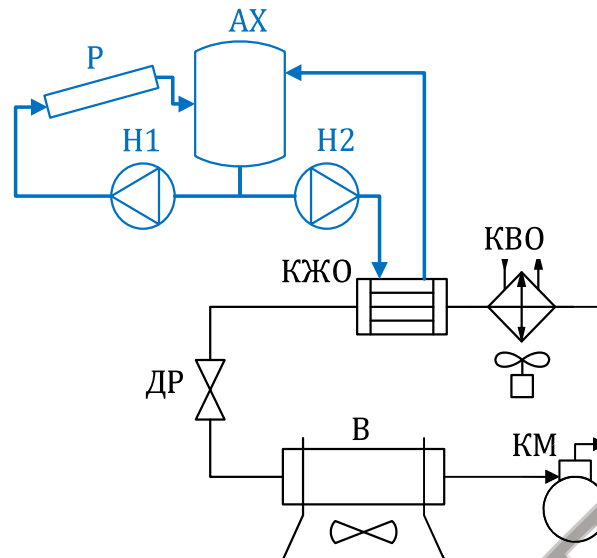

AX - cold accumulator; B - air cooler; ДР - throttling device;
 KЖО - air-cooled condenser; LCC - liquid-cooled condenser;
 KM - compressor; H1 - pump supplying coolant to radiator;
 H2 - pump, supplying coolant to RCC; P - radiator
 Figure 4 - Schematic diagram of the refrigeration system

The system works as follows. At night time the pump H1 switches on. It takes the coolant from the coolant accumulator and pumps it through the radiator P. The coolant is cooled, and then returns to the coolant accumulator AX. At this time the SCRM operates with air cooling condenser: compressor KM is on, fan KVO is on, fan of air cooler BO is on.

In the daytime (after sunrise) the H1 pump is switched off. In the period when the atmospheric air temperature becomes high enough, pump H2 is switched on. It takes the cooled coolant from the cool accumulator AX and conveys it to the condenser of liquid cooling CIC. Here the coolant removes heat from the condensing refrigerant and heats itself. After that, the coolant returns to the AH accumulator. During this period SCRM remains switched on: KM compressor is on, KBO fan is on, B air cooler fan is on.

Rated cooling capacity of the system under consideration is 10 kW.

Characteristics of the main elements and the developed mathematical model of the refrigeration system are presented in appendix B. The mathematical model is based on the method of solving thermal balance of its elements and estimating the thermodynamic cycle of a refrigerating machine, and makes it possible to select the main elements of the refrigerating system, to determine their estimated cost and consumed electric power.

3.2 Results of modeling

Let us model operation of a refrigeration system for given values of a rated temperature head at SCC $\Delta t_{KЖО.nom}$ (2,5...7,5 K), duration of use of a coolant from the coolant accumulator for SCC cooling τ_{ah} (1...12 hours), temperature change in the coolant accumulator per cycle Δt_{ah} (2...12 K).

Let us compare the results of modeling with the results of modeling of an ordinary refrigerating machine with air-cooled condenser. This common SCRM operates on refrigerant R404, has the same dependence of compressor refrigerating factor on condensing temperature, its nominal discharge in air-cooled condenser is 10°C, refrigerant boiling point is -10°C. Its mathematical model is also presented in appendix B.

Assuming that the radiators can be used to dissipate condensing heat throughout the summer (about 90 days per year), extremely long payback periods for the system are obtained.

In the proposed range of changeable parameters, the energy consumption of the system with condensation heat extraction is 88.1...99.1 % of the energy consumption of an ordinary SCRM. I.e., removal of condensation heat in all cases leads to energy saving (by 11.9% at most). The indicated level of energy saving is lower than that indicated in [15] (up to 21%).

In the proposed range of changeable parameters, the cost of additional elements of the refrigeration system (cold accumulator, radiators, pumps, liquid-cooling condenser) is from 1492.7 to 22 842 USD.

Proceeding from the condition of minimizing the payback period we have:

- 1) optimal duration of liquid cooling condenser operation is 5...6 hours.
- 2) area of a liquid-cooling condenser shall be taken as maximally possible on the assumption, that temperature head on it will make 2,5 ... 5 °C.
- 3) Changing of temperature in the accumulator of cold during a day should be accepted as maximally possible at the level of about 10°C.

Table 2 - Characteristics of the system at the optimum value of the parameters to be changed

№	Parameter	Measurement unit.	Meaning
1	Liquid cooling condenser area	m ²	2,26
2	Weight of cold accumulator	kg	5290
3	Heat sink area	m ²	84
4	Volume flow of pump H1	m ³ /h	1,93
5	Volume flow of pump H2	m ³ /h	13,73
6	Energy consumption of the system per day	kWh	115,7
7	Liquid cooling condenser cost	USD	755
8	The cost of the accumulator of cold	USD	831,8
9	The cost of the cooler	USD	3815,6
10	Cost of H1 pump	USD	628,2
11	Cost of pump H2	USD USD	86,1
12	Cost of all additional elements of the system	USD USD	6116,7
13	Payback time	years	260,7

The payback period of the refrigeration system should have a value of no more than 10 years, due to the planned service life of the system components. So that the proposed system with condensation heat extraction could pay for itself within the allotted period if the cost of electricity was 25 times higher than the current value.

At optimal parameters ($\Delta t_{(KJO.nom)}=2,5^{\circ}\text{C}$; $\tau_{ah}=5$ hours; $\Delta t_{ah} = 10^{\circ}\text{C}$) we have the system characteristics presented in table 2.

3.3 Drainage of all condensation heat into the RAC

The FHE fan during its operation consumes additional energy. If it is switched off, the amount of heat entering the cold accumulator will increase. Consequently, the mass of the cold accumulator must increase, which will increase the cost of the system. The area of the FHE will also need to be increased. The flow rate of the coolant through the FLC, and the power consumed by the H2 pump will increase.

With optimum values of variable parameters, obtained earlier, and deactivation of the FHE during CWC operation, we obtain parameters according to Table 3.

Table 3 - Parameters of the system, if the BHE is on, when the LWC is running, and if the BHE is off, when the LWC is running

No	Parameter	Measurement unit.	EHE is on	EHE is off	Modified.
1	Liquid cooling condenser area	m ²	2,25	2,75	+22%
2	Weight of cold accumulator	kg	4808	5863	+22%
3	Heat sink area	m ²	76	93	+22%
4	Volume flow of pump H1	m ³ /h	13,74	16,75	+22%
5	Volume flow of pump H2	m ³ /h	1,92	2,36	+23%
6	Energy consumption of the system per day	kWh	115,72	112,82	-2,6%
7	Liquid cooling condenser cost	USD	755	863	+14%
8	The cost of the accumulator of cold	USD	831	1018	+22%
9	The cost of the cooler	USD	3815	4653	+22%
10	Cost of H1 pump	USD	628,2	682,9	+9%
11	Cost of pump H2	USD USD	86,1	140,8	+63%
12	Cost of all additional elements of the system	USD USD	6117	7362	+20%
13	Payback time	years	260,7	222,1	-17%

From a practical point of view, an increase in the area of the liquid-cooled condenser, an increase in the weight of the refrigerant accumulator, an increase in the volume flow of the pumps can be considered insignificant. Total cost of additional

elements of the refrigeration system will increase by 20%. However, the payback period of the system will decrease by 17%.

From this it can be concluded that the system should be designed in such a way that the CWC takes all the condensation heat during the daytime and the air-cooled condenser is disconnected at the same time.

3.4 Comparison of refrigerants R134a and R404a

When using R134a refrigerant, a compressor with a volumetric capacity of 32.48 m³/h is required. When using R404 refrigerant, the required compressor volumetric capacity is only 16,24 m³/hour. At that, when using hermetic Danfoss compressors at condensation temperature within the range of +30...+40°Ñ with R134a refrigerant, there is no increase of energy effectiveness as compared to R404a refrigerant.

In a system with condensation heat removal due to RO, condensation temperature will always be lower than +40°C. Therefore, in case of using hermetic compressor, R134a refrigerant is not advisable to use in the system with condensation heat removal due to radiation cooling.

While using piston semi-hermetic compressors of Bitzer 2CES and 4CES, refrigerating factor of R134a will be 6% higher than that of R404a. However, for R134a refrigerant, it requires almost a twofold increase in compressor volumetric capacity. Because of this, the compressor in the system on R134a refrigerant will be much more expensive (by 50...60%). It will also be necessary to increase the area of condenser of liquid cooling. Also in this case, energy savings per day will be only 3,6 %. As a result, the payback period of the refrigeration system will increase by 2.1 times. Consequently, using RO for condensation heat removal in the system with the refrigerant R134a is less profitable than in the system with the refrigerant R404a.

4. Conclusions

There has been made a computer modeling of a refrigeration system operation with a condensation heat removal at the expense of RH under summer climate conditions in Shymkent city. It is established that the peak condensation temperature in the daytime can be reduced to 32.5 ° C instead of 46 ° C when using an air-cooled condenser.

The shortest payback period of the developed system is observed when the temperature in the refrigeration accumulator during a day changes to 10°C, the temperature head at the liquid cooling condenser is 2.5°C and the duration of operation of the liquid cooling condenser during a day is equal to 5 hours.

At an optimum value of the system's variable parameters, the daily power consumption of the system is reduced by 5.8% compared with an ordinary PCCM, and the cost of the additional elements of the system (cold accumulator, pumps, radiators) is about 8076 USD. At the current level of electric power tariffs, the specified level of energy saving does not provide payback of a refrigeration system with condensation heat removal at the expense of RO in a reasonable time. Therefore, the proposed system can be recommended to be used only for reduction of risk of emergency shutdown of a refrigerating machine in the daytime at maximum temperature of atmospheric air on

objects, where there are no available sources of fresh water, suitable for cooling of evaporative condensers.

Long payback period of the system is due to the high cost of radiators (about 50 USD/m²) and cold accumulator.

It is also found that the air-cooled condenser fan should be turned off when the liquid-cooled condenser is running, as this will reduce the energy consumption and payback period of the system. At the same time, the liquid-cooling condenser must discharge all of the refrigerant condensation heat into the refrigerant accumulator.

Using of condensation heat removal scheme from the economic point of view is more reasonable in the systems operating on R404a refrigerant. If R134a refrigerant is charged into the system, payback period of condensation heat transfer scheme is considerably prolonged (2,1 times).

In future it is necessary to study a possibility of using radiators with selective covering of the radiating surface [29], which can provide its twenty-four-hour operation and also make it possible to reduce the mass of a cold accumulator.

5. LIST OF SOURCES USED

- 1 Жумагазиев, А.З. Будущее Казахстана – развитие источников перспективной энергетики / А. З. Жумагазиев, А. У. Абулгазиев, Ж. К. Кадашева // Наука и образование в глобальных процессах. – 2016. – № 1(3). – С. 8–11.
- 2 Гельманова, З.С. Условия формирования устойчивой энергетики в Казахстане / З. С. Гельманова, М. К. Ибатов, К. А. Ногаев // Int. J. Appl. Fundam. Res. – 2016. – № 7. – С. 858–864.
- 3 Соколов, В.С. Экологический аспект кондиционирования воздуха промышленных объектов / В. С. Соколов, И. В. Зайченко // Дальневосточная весна – 2018: Материалы 16-й Международной научно–практической конференции по проблемам экологии и безопасности. – Комсомольск-на-Амуре: Комсомольский-на-Амуре государственный технический университет, 2018. – С. 134–136.
- 4 Catalanotti, S. The radiative cooling of selective surfaces / S. Catalanotti, V. Cuomo, G. Piro, D. Ruggi, V. Silvestrini, G. Troise // Sol. Energy. 1975. – Vol. 17, № 2. – P. 83–89. – DOI: 10.1016/0038-092X(75)90062-6.
- 5 Kimball, B. Cooling performance and efficiency of night sky radiators // Sol. energy. – 1985. – Vol. 34, № 1. – P. 19–33. – DOI: 10.1016/0038-092X(85)90089-1.
- 6 Samuel, D.G.L. Passive alternatives to mechanical air conditioning of building: A review / D. G. L. Samuel, S. M. S. Nagendra, M. P. Maiya // Build. Environ. – 2013. – Vol. 66. – P. 54–64. – DOI: 10.1016/j.buildenv.2013.04.016.
- 7 Zhao, B. Radiative cooling: A review of fundamentals, materials, applications, and prospects / B. Zhao, H. Mingke, X. Ao, N. Chen, G. Pen // Appl. Energy. – 2019. – Vol. 236. – P. 489–513. – DOI: 10.1016/j.apenergy.2018.12.018.
- 8 Ahmad, M. I. Nocturnal Cooling Technology for Building Applications / M.I. Ahmad, H. Jarimi, S. Riffat. – Singapore: Springer, 2019. – 77 p. – DOI: 10.1007/978-981-13-5835-7.
- 9 Etzion, Y. Thermal storage mass in radiative cooling systems / Y. Etzion, E. Erell // Build. Environ. – 1991. – Vol. 26, № 4. – P. 389–394.
- 10 Mihalakakou, G. The cooling potential of a metallic nocturnal radiator / G. Mihalakakou, A. Ferrante, J.O. Lewis // Energy Build. – 1998. – Vol. 28, № 3. – P. 251–256. – DOI: 10.1016/S0378-7788(98)00006-1.
- 11 Tsoy A. P. Effectiveness of a night radiative cooling system in different geographical latitudes / A.P. Tsoy, A.S. Granovskiy, A.V. Baranenko, D.A. Tsoy // AIP Conference Proceedings. – 2017. – Vol. 1876. – 020060. – DOI: 10.1016/0038-092X(85)90089-1.

- 12 Qingyuan, Z. Potentials of Passive Cooling for Passive Design of Residential Buildings in China / Z. Qingyuan, L. Yu // *Energy Procedia*. – 2014. – Vol. 57. – P. 1726–1732. – DOI: 10.1016/j.egypro.2014.10.161.
- 13 Farmahini Farahani, M. A two-stage system of nocturnal radiative and indirect evaporative cooling for conditions in Tehran / M. Farmahini Farahani, G. Heidarinejad, S. Delfani // *Energy Build.* – 2010. – Vol. 42, № 11. – P. 2131–2138. – DOI: 10.1016/0038-092X(85)90089-1.
- 14 Zhang, K. Energy saving and economic analysis of a new hybrid radiative cooling system for single-family houses in the USA / K. Zhang, D. Zhao, X. Yin, R. Yang, G. Tan // *Appl. Energy*. – 2018. – Vol. 224. – P. 371–381. – DOI: 10.1016/j.apenergy.2018.04.115.
- 15 Goldstein, E. A. Sub-ambient non-evaporative fluid cooling with the sky / E.A. Goldstein, A.P. Raman, S. Fan // *Nat. Energy*. – 2017. – Vol. 2. – P. 1–7. – DOI: 10.1038/nenergy.2017.143.
- 16 Karagusov, V. I. Experimental stand for investigation of the radiation life – support systems: First experiments / V.I. Karagusov, R. Yu. Goshlya, V.S. Serdyuk, I.S. Kolpakov, V.A. Nemykin, I.N. Pogulyaev // *AIP Conf. Proc.* – 2018. – Vol. 2007. – P. 030014. – DOI: 10.1063/1.5051875.
- 17 Karagusov, V. I. Experimental determination of rate and direction of heat flow of the radiation life – Support system with vacuum heat insulation / V. I. Karagusov, V. S. Serdyuk, I. S. Kolpakov, V. A. Nemykin, I. N. Pogulyaev // *AIP Conf. Proc.* – 2018. – Vol. 2007. – P. 030015. – DOI: 10.1063/1.5051876.
- 18 Пат. WO 2006/054897 A1, МПК F25B 23/00, F25B 25/00, Refrigeration or cooling system / S. M. van der Sluis, P. A. Oostendorp, L. J. Hendriksen. – заявл. 22.11.2005; опублик. 26.05.2006.
- 19 Fumo, N. Energy and economic evaluation of cooling, heating, and power systems based on primary energy / N. Fumo, P. J. Mago // *Appl. Therm. Eng.* 2009. – Vol. 29, № 13. – P. 2665–2671. – DOI: 10.1063/1.5051876.
- 20 Fumo, N. Emission operational strategy for combined cooling, heating, and power systems / N. Fumo, P. J. Mago, L. M. Chamra // *Appl. Energy*. – 2009. – Vol. 86, № 11. – P. 2344–2350. – DOI: 10.1016/j.apenergy.2009.03.007.
- 21 Zhang, Sh. Cooling performance of nocturnal radiative cooling combined with microencapsulated phase change material (MPCM) slurry storage / S. Zhang, J. Niu // *Energy Build.* – 2012. – Vol. 54. – P. 122–130. – DOI: 10.1016/j.enbuild.2012.07.041.
- 22 Al-Nimr, M. A theoretical and experimental investigation of a radiative cooling system / M. Al-Nimr, Z. Kodah, B. Nassar // *Sol. Energy*. – 1998. – Vol. 63. – P. 367–373.
- 23 Zhao, D. Development of a single-phase thermosiphon for cold collection and storage of radiative cooling // *Appl. Energy*. – 2017. – Vol. 205. – P. 1260–1269.
- 24 Liu, Z. Experimental investigation on night sky radiant cooling performance of duct-type heat exchanger / Z. Liu, H. Tan, G. Ma // *Int. J. Vent.* – 2017. – Vol. 16, № 3. – P. 255–267. – DOI: 10.1080/14733315.2017.1299520.
- 25 Ali, A. H. H. Cooling of water flowing through a night sky radiator / A. H. H. Ali, I. M. Taha, I. M. Ismail // *Sol. Energy*. – 1995. – Vol. 55. – P. 235–253.
- 26 Tevar, J. a. F. Modelling and experimental analysis of three radioconvective panels for night cooling / J. A. Ferrer Tevar, S. Castano, A. Gorrido Marijuan, M. R. Heras, J. Pistono // *Energy Build.* – 2015. – Vol. 107. – P. 37–48. – DOI: 10.1016/j.enbuild.2015.07.027.
- 27 Meir, M. G. A study of a polymer-based radiative cooling system / M. G. Meir, J. B. Rekstad, O. M. Løvvik // *Sol. Energy*. – 2002. – Vol. 73, № 6. – P. 403–417. – DOI: 10.1016/S0038-092X(03)00019-7.
- 28 Bergman, T. L. Active daytime radiative cooling using spectrally selective surfaces for air conditioning and refrigeration systems // *Sol. Energy*. 2018. – Vol. 174. – P. 16–23.

- 29 Zhao, D. Subambient Cooling of Water: Toward Real-World Applications of Daytime Radiative Cooling / D. Zhao, A. Aili, Y. Zhai, J. Lu, D. Kidd, G. Tan, X. Yin, R. Yang // *Joule*. – 2019. – Vol. 3, № 1. – P. 111–123. – DOI: 10.1016/j.joule.2018.10.006.
- 30 Tsoy, A. P. Operation of refrigerating installations units with air condensers under climate conditions of Kazakhstan (Russian) / A. P. Tsoy, A. Ya. Eglit // *Kholodilnaya Tekhnika*. – 2013 – № 6. – P. 77–82.
- 31 Borisova, E. A. Central Asia: water scarcity as a security threat (Russian) // *Eastern Analytics*. – 2011. – № 2. – P. 211–217.
- 32 Кеншимов, А. Анализ отрасли “Водное хозяйство”. – Алматы: Консорциум ассоциаций АПК, 2019. – 99 с.
- 33 Zhu, K. Techno-economic feasibility of integrating energy storage systems in refrigerated warehouses / K. Zhu, X. Li, P. E. Campana, H. Li, J. Yan // *Appl. Energy*. – 2018. – Vol. 216. – P. 348–357. – DOI: 10.1016/j.apenergy.2018.01.079.
- 34 Tsoy, A. P. Simulation of radiation cooling system for air conditioning (Russian) / A. P. Tsoy, A. S. Granovskiy, D. A. Tsoy, A. V. Baranenko // *Vestnik Mezhdunarodnoi akademii kholoda*. – 2019. – № 3. – P. 3–14. – DOI: 10.17586/1606-4313-2019-18-3-3-14.
- 35 Расписание погоды rp5: Архив данных о погоде по городам мира. [Электронный ресурс]. – 2019. – URL: <http://rp5.kz> (дата обращения: 13.10.2020).
- 36 Баранчикова, С. Г. Экономическая эффективность технических решений: учебное пособие / под. ред. Ершова И.В. – Екатеринбург: Изд-во Урал. Ун-та, 2016. – 140 с.
- 37 Пат. KZ U 4789, МПК F25B 25/00, F25B 23/00. Система хладоснабжения с радиационным отводом теплоты / А. П. Цой, А. С. Грановский, Д. А. Цой. – заявл. 02.10.2018; опубл. 13.03

TECHNICAL COMPARISON OF INFRARED HEATERS OF LONG-WAVE RANGE Authors: Hanna Rybakova, Maksym Syrovatskyi, Denys Pavlenko Advisors: Andrii Ivakhnov, Olexii Bulhakov National Technical University "Kharkiv Polytechnic Institute" (Ukraine).....	582
EFFICIENCY IMPROVING OF MARINE ENGINES BY USING A CONTACT COOLING SYSTEM WITH A THERMOPRESSOR Authors: Dmytro Sydorenko, Illia Nadtochii Advisors: Halina Kobalava, Dmytro Konovalov Kherson Educational-Scientific Institute of Admiral Makarov National University of Shipbuilding (Ukraine).....	592
DEVELOPMENT OF THE AUTOMATED ELECTRIC DRIVE OF THE MINERAL FERTILIZER LOADER WITH DEVELOPMENT OF THE CONTROL SYSTEM Author: Artem Musienko, Ivan Bartholomew Advisor: Aleksey Sadovoy Mykolayiv National Agrarian University (Ukraine).....	607
IMPROVEMENT OF THE REFRIGERATION SYSTEM WITH RADIATIVE COOLING AND COMBINED CONDENSATION Author: Aleshchenko Mikhail Advisor: Tsoy Alexander Almaty Technological University (Kazakhstan).....	627
DEVELOPMENT OF ENERGY-EFFICIENT VIBRATION PLANT FOR DRYING SUNFLOWER SEEDS BASED ON INFRARED RADIATION Author: Ivan Nadkrenychnyi ¹ Advisors: Valentyna Bandura ¹ , Sree Gundebommu ² ¹ National University of Life and Environmental Sciences of Ukraine ² CVR Hyderabad College of Engineering (Republic of India).....	639
5. ECOLOGY AND ENVIRONMENTAL PROTECTION.....	650
MODIFICATION OF ANAEROBIC DIGESTION USING RICE HUSK Authors: Luferova Olena ¹ , Mariami Aleksidze ² Advisors: Irina Kuznetsova ¹ , Davitashvili Magda ² ¹ Odessa National Technological University (Ukraine) ² Iakob Gogebashvili Telavi State University (Georgia).....	651
THE ORGANIC PART OF MUNICIPAL SOLID WASTES' COMPOSTING USING SOIL MICROORGANISMS Authors: Petrenko Elizaveta ¹ , Anželika Dautartė ² Advisors: Olga Sagdeeva ¹ , Laima Cesoniene ² ¹ College of Oil and Gas Technologies, Engineering, and Service Infrastructure of the Odessa National Academy of Food Technologies (Ukraine) ² Vytautas Magnus University Agriculture Academy (Lithuania).....	660